

ELEVATION CERTIFICATE

Important: Follow the instructions on pages 1-9.

Copy all pages of this Elevation Certificate and all attachments for (1) community official, (2) insurance agent/company, and (3) building owner.

SECTION A – PROPERTY INFORMATION		FOR INSURANCE COMPANY USE
A1. Building Owner's Name Landmark 24 Homes	Policy Number:	
A2. Building Street Address (including Apt., Unit, Suite, and/or Bldg. No.) or P.O. Route and Box No. 643 Wyndham Way	Company NAIC Number:	
City Pooler	State Georgia	ZIP Code 31322
A3. Property Description (Lot and Block Numbers, Tax Parcel Number, Legal Description, etc.) Lot 490, Forest Lakes, PH 6, 8th G.M. District, City of Pooler, Chatham County, Georgia, PIN: 5-1014C-06-034 (Plat Book 50, Page 758)		
A4. Building Use (e.g., Residential, Non-Residential, Addition, Accessory, etc.) Residential		
A5. Latitude/Longitude: Lat. 32.14491 Long. -81.27607 Horizontal Datum: <input type="checkbox"/> NAD 1927 <input checked="" type="checkbox"/> NAD 1983		
A6. Attach at least 2 photographs of the building if the Certificate is being used to obtain flood insurance.		
A7. Building Diagram Number 1B		
A8. For a building with a crawlspace or enclosure(s):		
a) Square footage of crawlspace or enclosure(s) N/A sq ft		
b) Number of permanent flood openings in the crawlspace or enclosure(s) within 1.0 foot above adjacent grade N/A		
c) Total net area of flood openings in A8.b N/A sq in		
d) Engineered flood openings? <input type="checkbox"/> Yes <input checked="" type="checkbox"/> No		
A9. For a building with an attached garage:		
a) Square footage of attached garage 442 sq ft		
b) Number of permanent flood openings in the attached garage within 1.0 foot above adjacent grade 3		
c) Total net area of flood openings in A9.b 672 sq in		
d) Engineered flood openings? <input checked="" type="checkbox"/> Yes <input type="checkbox"/> No		

SECTION B – FLOOD INSURANCE RATE MAP (FIRM) INFORMATION					
B1. NFIP Community Name & Community Number City of Pooler 130261		B2. County Name Chatham		B3. State Georgia	
B4. Map/Panel Number 13051C0019	B5. Suffix H	B6. FIRM Index Date July 7, 2014	B7. FIRM Panel Effective/ Revised Date July 7, 2014	B8. Flood Zone(s) AE	B9. Base Flood Elevation(s) (Zone AO, use Base Flood Depth) 20.0'
B10. Indicate the source of the Base Flood Elevation (BFE) data or base flood depth entered in Item B9: <input type="checkbox"/> FIS Profile <input checked="" type="checkbox"/> FIRM <input type="checkbox"/> Community Determined <input type="checkbox"/> Other/Source: _____					
B11. Indicate elevation datum used for BFE in Item B9: <input type="checkbox"/> NGVD 1929 <input checked="" type="checkbox"/> NAVD 1988 <input type="checkbox"/> Other/Source: _____					
B12. Is the building located in a Coastal Barrier Resources System (CBRS) area or Otherwise Protected Area (OPA)? <input type="checkbox"/> Yes <input checked="" type="checkbox"/> No Designation Date: _____ <input type="checkbox"/> CBRS <input type="checkbox"/> OPA					

ELEVATION CERTIFICATE

OMB No. 1660-0008
Expiration Date: November 30, 2018

IMPORTANT: In these spaces, copy the corresponding information from Section A.			FOR INSURANCE COMPANY USE
Building Street Address (including Apt., Unit, Suite, and/or Bldg. No.) or P.O. Route and Box No. 643 Wyndham Way			Policy Number:
City Pooler	State Georgia	ZIP Code 31322	Company NAIC Number

SECTION E – BUILDING ELEVATION INFORMATION (SURVEY NOT REQUIRED) FOR ZONE AO AND ZONE A (WITHOUT BFE)

For Zones AO and A (without BFE), complete Items E1–E5. If the Certificate is intended to support a LOMA or LOMR-F request, complete Sections A, B, and C. For Items E1–E4, use natural grade, if available. Check the measurement used. In Puerto Rico only, enter meters.

- E1. Provide elevation information for the following and check the appropriate boxes to show whether the elevation is above or below the highest adjacent grade (HAG) and the lowest adjacent grade (LAG).
- a) Top of bottom floor (including basement, crawlspace, or enclosure) is _____ feet meters above or below the HAG.
 - b) Top of bottom floor (including basement, crawlspace, or enclosure) is _____ feet meters above or below the LAG.
- E2. For Building Diagrams 6–9 with permanent flood openings provided in Section A Items 8 and/or 9 (see pages 1–2 of Instructions), the next higher floor (elevation C2.b in the diagrams) of the building is _____ feet meters above or below the HAG.
- E3. Attached garage (top of slab) is _____ feet meters above or below the HAG.
- E4. Top of platform of machinery and/or equipment servicing the building is _____ feet meters above or below the HAG.
- E5. Zone AO only: If no flood depth number is available, is the top of the bottom floor elevated in accordance with the community's floodplain management ordinance? Yes No Unknown. The local official must certify this information in Section G.

SECTION F – PROPERTY OWNER (OR OWNER'S REPRESENTATIVE) CERTIFICATION

The property owner or owner's authorized representative who completes Sections A, B, and E for Zone A (without a FEMA-issued or community-issued BFE) or Zone AO must sign here. The statements in Sections A, B, and E are correct to the best of my knowledge.

Property Owner or Owner's Authorized Representative's Name			
Address	City	State	ZIP Code
Signature	Date	Telephone	

Comments

Check here if attachments.

ELEVATION CERTIFICATE

BUILDING PHOTOGRAPHS

See Instructions for Item A6.

OMB No. 1660-0008

Expiration Date: November 30, 2018

IMPORTANT: In these spaces, copy the corresponding information from Section A.			FOR INSURANCE COMPANY USE
Building Street Address (including Apt., Unit, Suite, and/or Bldg. No.) or P.O. Route and Box No. 643 Wyndham Way			Policy Number:
City Pooler	State Georgia	ZIP Code 31322	Company NAIC Number

If using the Elevation Certificate to obtain NFIP flood insurance, affix at least 2 building photographs below according to the instructions for Item A6. Identify all photographs with date taken; "Front View" and "Rear View"; and, if required, "Right Side View" and "Left Side View." When applicable, photographs must show the foundation with representative examples of the flood openings or vents, as indicated in Section A8. If submitting more photographs than will fit on this page, use the Continuation Page.



Photo One Caption

FRONT VIEW 2/28/2018



Photo Two Caption

REAR VIEW 2/28/2018

ELEVATION CERTIFICATE

BUILDING PHOTOGRAPHS

Continuation Page

OMB No. 1660-0008
Expiration Date: November 30, 2018

IMPORTANT: In these spaces, copy the corresponding information from Section A.			FOR INSURANCE COMPANY USE
Building Street Address (including Apt., Unit, Suite, and/or Bldg. No.) or P.O. Route and Box No. 643 Wyndham Way			Policy Number:
City Pooler	State Georgia	ZIP Code 31322	Company NAIC Number

If submitting more photographs than will fit on the preceding page, affix the additional photographs below. Identify all photographs with: date taken; "Front View" and "Rear View"; and, if required, "Right Side View" and "Left Side View." When applicable, photographs must show the foundation with representative examples of the flood openings or vents, as indicated in Section A8.



Photo One Caption

LEFT VIEW 2/28/2018



Photo Two Caption

RIGHT VIEW 2/28/2018



Code Compliance Research Report CCRR-0239

Issue Date: 01-18-2016
Renewal Date: 01-18-2017

Valued Quality. Delivered.

DIVISION: 08 00 00 – OPENINGS
Section: 08 95 43 – Vents/Foundation Flood Vents

USA Floodair Vents, LTD.
63 Putnam Street, Suite 202
Saratoga Springs, New York 12866
(631) 269-1872
www.usafloodairvents.com

REPORT SUBJECT:

Model FOSS (Stainless steel flood vent)
Model FASS (Stainless steel flood vent with ventilation)
Model FOAL (Aluminum flood vent)
Model FAAL (Aluminum flood vent with ventilation)
Model ROAL (Retro-fit Aluminum flood vent)

1.0 SCOPE OF EVALUATION

This research report addresses compliance with the following Codes:

2012 International Building Code (IBC)

2012 International Resident Code (IRC)

2014 Florida Building Code (FBC)

Foundation Flood Vents have been evaluated for the following properties:

- Physical Operation
- Water Flow
- Ventilation

2.0 USES

2.1. USA Floodair Vents units are flood vents that operate on hydrostatic pressure to equalize hydrostatic flood forces on exterior walls by allowing for the automatic entry and exit for flood waters. These vents have been established in use where flood areas have been established in accordance with IBC Section 1612.3 or IRC Section R3222.1. Some *USA Floodair Vents* models have perforated doors to provide air ventilation in a crawl space in order to increase air flow

while still providing flood protection *in accordance with Section 1203.3.1 of the IBC or Section 408.2 of the IRC.* See Ventilation in the Description Section for clarification.

3.0 DESCRIPTION

3.1. General: The *USA Floodair Vents* units are engineered openings when subjected to a hydrostatic force to open to allow flood waters to flow through the vent in order to equalize hydrostatic flood forces on the exterior walls. The solid or perforated doors swing open, disengaging from the bottom of the frame, allowing flood waters to flow through the frame. Each unit is fabricated from either stainless steel or aluminum. *USA Floodair Vents* models consist of two parts, a frame and a vent door.

3.2. Engineered Opening: The *USA Floodair Vents* units comply with the design principle noted in Section 2.6.2.2 of ASCE/SEI 24 for a maximum rate of rise and fall of 5.0 feet per hour (0.423 mm/s). In order to comply with the engineered opening requirements of ASCE/SEI 24, the *USA Floodair Vents* units must be installed in accordance with Section 4.0 of this report.

3.3. Model Sizes: Models FOSS, a stainless steel flood vent with no ventilation, measures 18 inches wide by 10 inches high (See Figure 1). Model FASS, a stainless steel flood vent with ventilation, measures 18 inches wide by 10 inches high (See Figure 2). Model FOAL, an aluminum flood vent with no ventilation, measures 18 inches wide by 10 inches high (See Figure 3). Model FAAL, an aluminum flood vent with ventilation, measures 18 inches wide by 10 inch high (See Figure 4). Model ROAL, an aluminum flood vent used for retrofitting with no ventilation, measures 16.37 inches wide by 10 inches high (See Figure 5).

3.4. Ventilation: *The USA Floodair Vents* models FASS and FAAL have ¼ inch diameter openings on the vent doors to provide air ventilation. Model FASS provides 28 square inches of net free area. Model FAAL provides 37 square inches of net free area. All other models in this report do not provide ventilation.

4.0 INSTALLATION AND PERFORMANCE

4.1. *USA Floodair Vents* units are to be installed in exterior walls in new and existing construction. Model ROAL is to be used for existing construction. Flood vents shall be installed in accordance with the manufacturer's instructions, the applicable code and this report. To meet the engineered opening design requirements found in Section 2.6.2.2 of ASCE/SEI 24, the *USA Floodair Vents* units must be installed as follows:

4.1.1. A minimum of two bi-directional flood vents are required for enclosed flood exposed areas and to be installed on opposite or adjacent walls.

4.1.2. Below the base flood elevation.

4.1.3. With the bottom of the *USA Floodair Vents* unit located at a maximum of 12 inches above grade.

4.1.4. With a minimum of one *USA Floodair Vents* unit for every 252 square feet for Models FOSS, FASS, FOAL, and FAAL and for every 224 square feet for Model ROAL.

5.0 SUPPORTING EVIDENCE

5.1. Manufacturer's drawings and installation instructions.

5.2. Reports of testing in accordance with ICC-ES AC364, Acceptance Criteria for Automatic Foundation Flood Vents, dated Approved October 2013. The reports of testing and engineering analysis demonstrating compliance with the performance requirements of AC364 and ASCE/SEI 24-05 (ASCE/SEI 24-14 for 2014 FBC).

5.3. Quality control manual in accordance with ICC-ES AC10, Acceptance Criteria for Quality Documentation, dated June 2014.

6.0 CONDITION OF USE

The *USA Floodair Vents* units applications identified in this report are deemed to comply with the intent of the provisions of the referenced building codes subject to the following conditions:

6.1. Installation shall be in accordance with the manufacturer's installation instructions and this report. Where the difference occur between this report and the manufacturer's installation instructions, this report shall govern.

6.2. The *USA Floodair Vents* units must not be used in the place of breakaway walls in coastal high hazard areas, but are permitted for use in conjunction with breakaway walls in other areas.

6.3. All products are manufactured in West Columbia, South Carolina by *USA Floodair Vents, LTD* in accordance with the manufacturer's approved quality control system with inspections by Intertek (IAS AA-676).

7.0 IDENTIFICATION

USA Floodair Vents units produced in accordance with this report shall be identified with labeling on the individual vents and/or packaging that includes the following information:

7.1. Name and/or trademark of manufacturer;

7.2. The Intertek Code Compliance Research Report mark and number (CCRR-0239).



This Code Compliance Research Report ("Report") is for the exclusive use of Intertek's Client and is provided pursuant to the agreement between Intertek and its Client. Intertek's responsibility and liability are limited to the terms and conditions of the agreement. Intertek assumes no liability to any party, other than to the Client in accordance with the agreement, for any loss, expense or damage occasioned by the use of this Report. Only the Client is authorized to permit copying or distribution of this Report and then only in its entirety, and the Client shall not use the Report in a misleading manner. Client further agrees and understands that reliance upon the Report is limited to the representations made therein. The Report is not an endorsement or recommendation for use of the subject and/or product described herein. This Report is not the Intertek Listing Report covering the subject product and utilized for Intertek Certification and this Report does not represent authorization for the use of any Intertek certification marks. Any use of the Intertek name or one of its marks for the sale or advertisement of the tested material, product or service must first be approved in writing by Intertek.

8.0 CODE COMPLIANCE RESEARCH REPORT USE

8.1. Approval of building products and/or materials can only be granted by a building official having legal authority in the specific jurisdiction where approval is sought.

8.2. Code Compliance Research Reports shall not be used in any manner that implies an endorsement of the product by Architectural Testing.

8.3. Reference to the Intertek website address: whdirectory.intertek.com is recommended to ascertain the current version and status of this report.

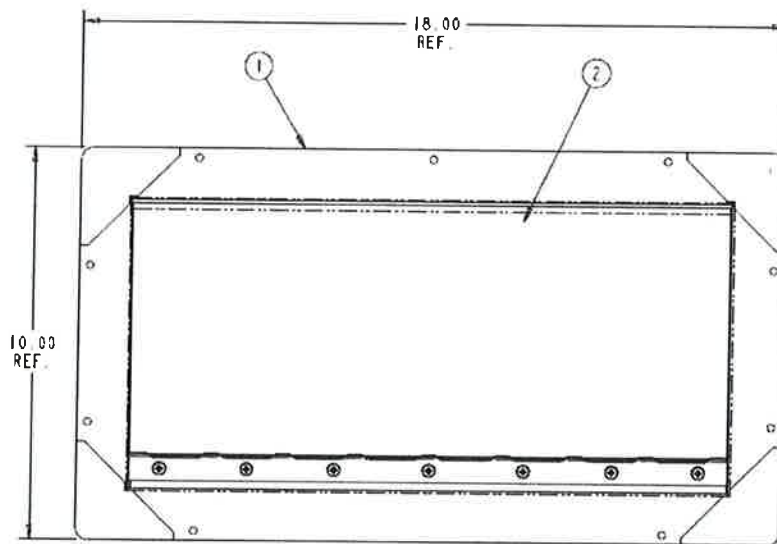

FIGURE 1 – FOSS Flood Vent

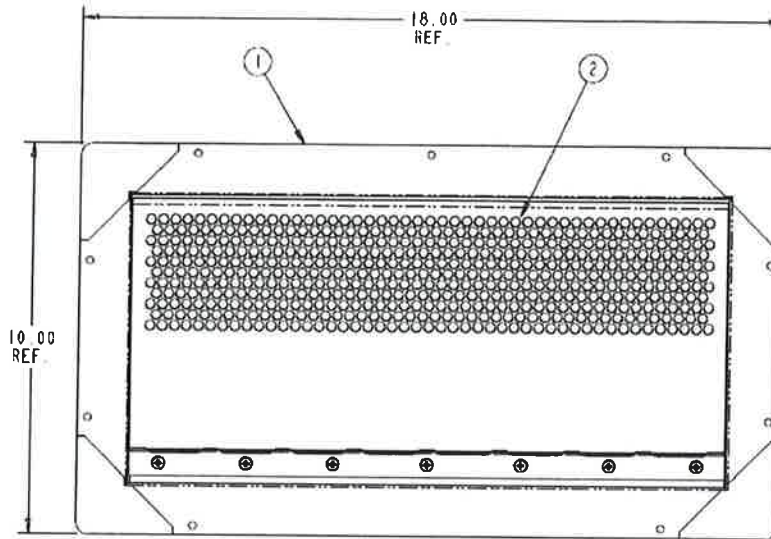

FIGURE 2 – FASS Flood Vent

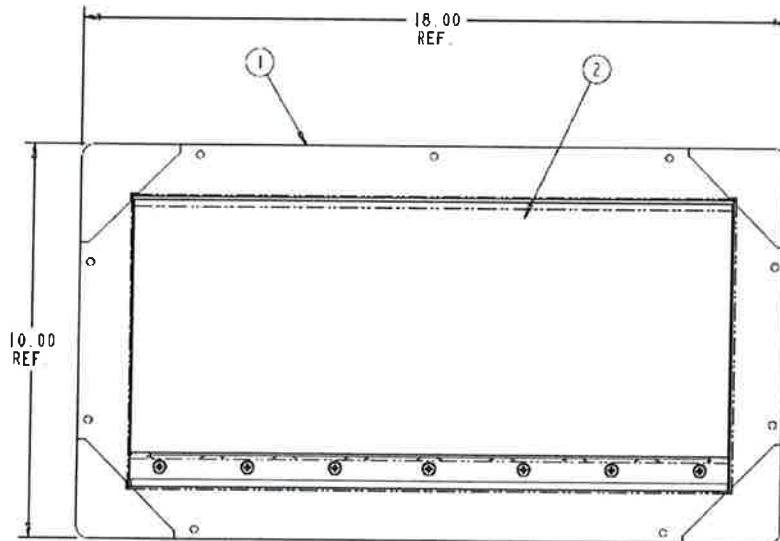

FIGURE 3 – FOAL Flood Vent

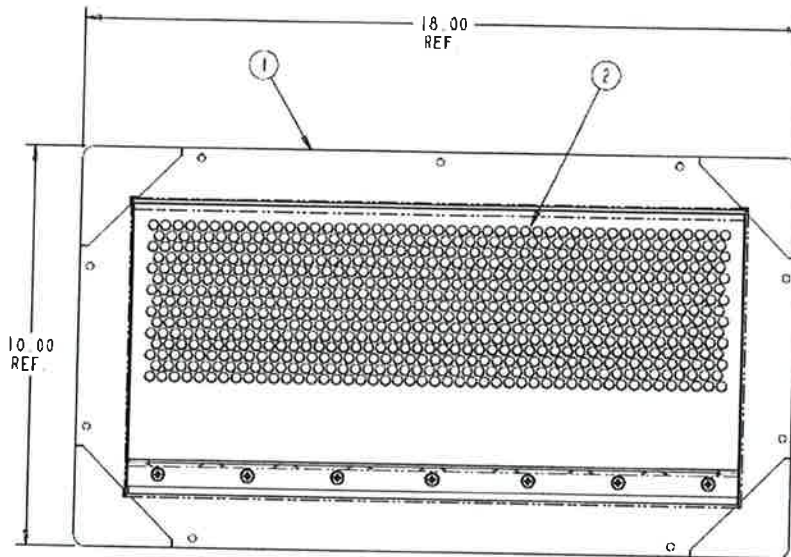

FIGURE 4 – FAAL Flood Vent

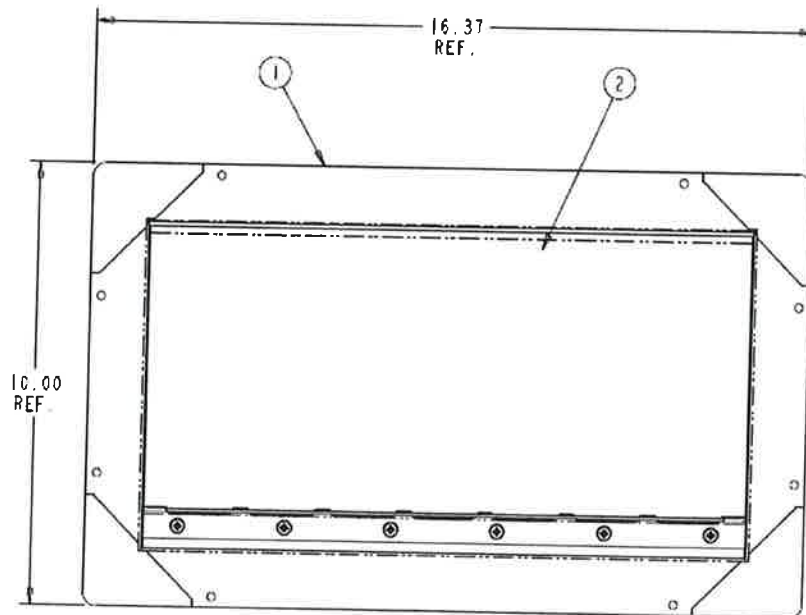

FIGURE 5 – ROAL Flood Vent